

# INSACCATRICE MECCANICA



## UTILIZZO

Per prodotti in polvere o granulari scorrevoli, per sacchi o contenitori a bocca aperta. Pesate da 5 a 50 kg, Da 120 a 350 pesate/ora (50-5 kg).

## COSTRUZIONE

- Costruite in acciaio inox
- Sistema omologato di pesatura
- Semplice utilizzo
- Minima manutenzione
- Comando a pedale

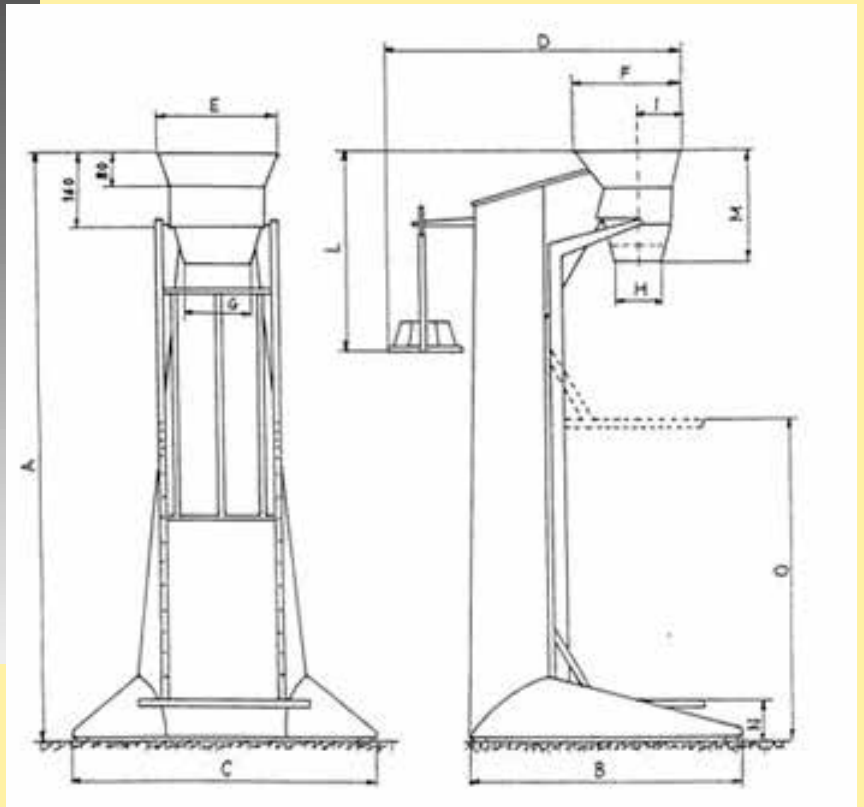

MODELLO	A mm	B mm	C mm	D mm	E mm	F m <sup>3</sup>	G mm	H mm	I mm	L mm	M mm	N mm	O mm
P50	1280	600	670	700	270	240	150	100	100	450	240	100	700
P50V	1280	600	670	700	270	240	180	130	100	450	240	100	700



**ZANIN F.lli s.r.l.** Viale delle Industrie, 1 - 31032 Casale sul Sile (TV) - Italy  
 Tel. +39 0422 785444 - Fax +39 0422 785805  
 www.zanin-italia.com info@zanin-italia.com



©2015 ZANIN F.lli - ATTENZIONE: DATI NON VINCOLANTI FARE RIFERIMENTO  
 ALLA SCHEDA TECNICA RILASCIATA DIRETTAMENTE DALLA ZANIN F.LLI

ZANIN-27-02-15

**RIVENDITORE**